



Investigating the efficiency and kinetic coefficients of nutrient removal in the subsurface artificial wetland of Yazd wastewater treatment plant

Mahdi Farzadkia¹, Mohammad Hassan Ehrampush², Ehsan Abouee Mehrizi³, Shahram Sadeghi⁴, Parvaneh Talebi⁵, Akbar Salehi⁵, Majid Kermani^{6*}

¹Professor, Department of Environmental Health Engineering, School of Public Health, Iran University of Medical Sciences, Tehran, Iran

²Professor, Department of Environmental Health Engineering, School of Public Health, Shahid Sadoughi University of Medical Sciences, Yazd, Iran.

³PhD Student, Environment Research Center, Department of Environmental Health Engineering, School of Public Health, Iran University of Medical Sciences, and Department of Environmental Health Engineering, Faculty of Public Health, North Khorasan University of Medical Sciences, Bojnurd, Iran.

⁴MSc Student, Department of Environmental Health Engineering, School of Public Health, Student Research Committee, Kurdistan University of Medical Sciences, Sanandaj, Iran.

⁵MSc Student, Department of Environmental Health Engineering, School of Public Health, Islamic Azad University, Maybod Branch, Maybod, Iran.

⁶Assistant Professor, Department of Environmental Health Engineering, School of Public Health, Iran University of Medical Sciences, Tehran, Iran.

Abstract

Background: Investigating the performance of naturally operated treatment plants may be due to the fact that they cannot be operated as desired, or that they should be modified to achieve good performance e.g. for nutrients removal. The advantage of kinetic coefficient determination is that the model can be adjusted to fit data and then used for analyzing alternatives to improve the process. This study investigates the efficiency of subsurface artificial wetland and determines its kinetic coefficients for nutrient removal.

Methods: The present study investigated the kinetics of biological reactions that occurred in subsurface wetland to remove wastewater nutrient. Samples were taken from 3 locations of wetlands for 6 months. The nutrient content was determined through measuring Total Kjeldahl Nitrogen (TKN), ammonium, nitrate, and phosphate values.

Results: Average levels for TKN, ammonium, nitrate, and phosphate in effluent of control wetland were 41.15, 23.59, 1.735, and 6.43 mg/L, and in wetland with reeds were 28.91, 19.99, 1.49 and 5.63 mg/L, respectively. First-order, second-order, and Stover-Kincannon models were applied and analyzed using statistical parameters obtained from the models (U_{max} , K_b).

Conclusion: The nutrients removal at Yazd wastewater treatment plant was remarkable, and the presence of reeds in wetland beds was not very efficient in improving system performance. Other more efficient plants are suggested to be evaluated in the system. Stover-Kincannon kinetic model provided predictions having the closest relationship with actual data obtained from the field.

Keywords: Wastewater, Wetland, Nutrients, Kinetic coefficients, Yazd

Citation: Farzadkia M, Ehrampush MH, Abouee Mehrizi E, Sadeghi S, Talebi P, Salehi A, et al. Investigating the efficiency and kinetic coefficients of nutrient removal in the subsurface artificial wetland of Yazd wastewater treatment plant. *Environmental Health Engineering and Management Journal* 2015; 2(1): 23–30.

Article History:

Received: 7 November 2014

Accepted: 20 January 2015

ePublished: 14 February 2015

*Correspondence to:

Majid Kermani

Email: majidkermani@yahoo.com

Introduction

The main aim of wastewater treatment is to produce suitable effluent to discharge into receiving environments, so that effluent discharge standards are followed, and no losses are imposed upon the receiving environments. By making water return to the consumption cycle directly, wastewater treatment protects the environment and improves general health. Given the importance of water crisis in this century, the vitality of wastewater treatment becomes more significant. Today, appropriate approaches

to wastewater treatment demand minimum costs and advanced technical facilities along with simplicity in operation (1).

The problems arising from municipal and industrial wastewater have been important for different societies (2–4). The major problems related to the common methods of municipal wastewater treatment are high energy consumption, high construction and operation costs, requirement for complex operations, requirement for sludge disposal and the use of mechanized systems which are nec-



essary for a treatment method using high-tech. However, not only doing natural wastewater treatment systems have the advantage of low technology and high performance, but also they rely on the existing natural and renewable energies like solar radiation, wind energy, energy stored in biomass, and soil (2,3,5,6). Some of natural wastewater treatment systems are natural systems of soil, aquatic systems, and reed system. They are frequently considered as 'black boxes' in which polluted waters are cleansed.

Wetlands fall into two groups: natural and artificial. Artificial wetlands seem to be one of the most appropriate technologies in developing countries since these systems enjoy features like resemblance to natural systems, simplicity of construction, ease of operation and maintenance, process stability, low sludge production and, low cost. Increased attention to natural processes, the necessity of treating the wastewater in sparsely populated areas, the use of public wastewater treatment, costs, operation, and maintenance needs are among the factors that have attracted public attention towards wetlands worldwide over the past 20 to 30 years. These systems have low initial costs and are easy in operation and maintenance (2,7,8).

The main difference between common systems of wastewater treatment and reed systems is in their speed. In common systems, in low volume reactors wastewater, treatment is quick, with high energy consumption and high management treated, while in aquatic systems and wetlands, treatment is conducted with less speed and basically without the need of natural environments (9,10). Currently, artificial wetlands are used in primary deposited wastewater treatment, secondary wastewater, third stage effluent treatment, disinfection, rural and urban surface wastewater management, toxic pollutant reduction management, landfills water leakage and mine wastewater treatment, sludge management, industrial wastewater treatment, nutrients removal from wastewater, nutrient excretion via biomass production, and groundwater supply. The presence of nitrogen in wastewater can be adverse for several reasons. Nitrogen, as free ammonia, is toxic to fish and many other aquatic organisms because nitrogen as ammonium ion or ammonia consumes oxygen, resulting in reduced dissolved oxygen in water. In terms of public health, the presence of nitrate ion in drinking-water is a potential risk for children. Given the local circumstances and conditions, removing all forms of nitrogen or just ammonium may be necessary. In biological treatment systems, both of the above objectives can be achieved economically. All forms of phosphorus and nitrogen are regarded as nutrients for aquatic plants, and thus have role in creating the phenomena called eutrophication (11,12). In a study done by Mayo and Bigambo in a subsurface artificial reed system, nitrogen removal model showed that 0.872 g of nitrogen per square meter was deposited in wetland floor system, on the sand bend, and in plant roots every day. However, 0.752 g of nitrogen per square meter deposited (86.2%) returned into the reed system process which means that only 13.8% nitrogen deposited is constantly removed. The total nitrogen removal rate in

this study was reported as 48.9%, 29.9%, 10.2%, and 8.2% (of net removal rate) of the removal rate were via denitrification, uptake by plants, and sedimentation in respect (13). In another study done by Brooks et al, phosphorous removal rate by subsurface reed system was reported to be more than 80%, and the concentration of phosphorus output dropped by 0.14-0.5 mm/L. These results were obtained for retention time of 40 hours while lower retention time showed 39% removal rate. In this research, a significant relationship was observed between retention time and phosphorous removal rate (14). Moreover, Miranzadeh et al study indicates that by increasing the system retention time from 2 days to 7 days in a subsurface reed system, the mean reduction of Total Phosphate (TP) increased from 12% to 36% in control wetland and 37% to 74% in the wetland with reeds (15). The problems of drinking water supply in most of Iranian provinces, the lack of proper management of wastewater, and the release of untreated wastewater into the environment suggest a growing need for the proper management of effluent and the prevention of its adverse impacts on our lives and environment. Hence, one of the most important environmental issues is to manage wastewater properly. Without knowing the status of treatment system, it is not possible to evaluate it properly. In this article, the performance of artificial wetland of Yazd city wastewater treatment plant has been examined with regard to nutrients removal. A large number of physical, chemical, and biological processes are involved in these systems influencing each other. These processes are not fully understood to date due to lack of appropriate models. The most widely employed modeling equations give only an exponential profile of inlet and outlet pollutant concentrations, without considering the full range of pollutant variability of engineered wetlands (16). This research also determined the kinetic coefficients of nitrogen and phosphorus and proposes the best model for the removal of studied parameters. The existing treatment plants may be investigated due to the fact that they cannot be directed as predicted and/or they must change for better performance. For example, they should be optimized in order to remove nutrients. There are many experiences about these analyses and determining kinetic coefficients. A model can be adjusted to fit the data and then used for the analysis of alternatives in order to improve the process. These analyses are used only for the development of experiences which contain a series of appropriate data for fitting the model. Models may be used as tools for the analysis of the information obtained from the similar studies. To achieve this goal, it is necessary to choose those models which describe studied processes in a special way, so that the better or the best interpretation is selected; that is the most generalizable interpretation (16).

Methods

Site specifications

The wastewater treatment plant of Yazd is located in the north of the city, close to the main road of Yazd airport. The latitudinal location of the Yazd Wastewater Stabili-

zation Ponds (WSPs) is about 34.08°N, the longitude is around 49.70 E, and the pond's altitude is 1710 m above sea level. Yazd treatment plant consists of three waste stabilization pond systems and artificial wetland (Figure 1). Figure 2 shows the arrangement of the units in the treatment plant. Table 1 presents the physical and operational characteristics of the wetland systems.

Sampling

This was a descriptive cross-sectional study carried out during 6 months including the cold-season months (from mid-January to mid-March) and warm-season months (from mid-May to early August in 2010-2011). The warm and cold months of the year were determined through the weather data of the previous years, and it was done upon natural treatment system (artificial wetland). In this research, some composite samples were taken, carried to the laboratory, and measured according to the standard methods in order to determine nutrients parameters in different points of the existing treating plant systems. From Yazd artificial wetland treatment system series, 4 beds were selected randomly. One bed did not have plants, and was used as the control bed, but the other three beds had reeds. All beds were designed with the same physical and hydraulic conditions. One bed was randomly chosen out of the beds with common reeds as the representative



Figure 1. Overview of treatment plant

of all beds (Bafgh local reeds). The beds were 12 meters long (the flow length) and 20 meters wide with a total surface area of 960 square meters. In this study, the wastewater output from septic tanks as wastewater input into the reed beds was sampled and analyzed. Sampling was done monthly for 6 consecutive months (wastewater output from septic (input into artificial wetland), wastewater output from control artificial wetland, and wastewater output from artificial wetland). All samples were taken in three sampling points located in the artificial bed, in three periods of time during a certain day, and each one was analyzed independently in order to increase the range of accurate data. Finally, in each sampling, three samples of the points (three samples for each point with different time frequencies) were taken for the determined parameters. Fifty-five samples were taken in total.

Climate

Yazd city has a relatively cold and dry climate. The maximum temperature may rise up to +38°C in summer and may fall to -10°C in winter. The average temperature in the coldest month is -7.48°C. The average precipitation is around 300 mm and the annual relative humidity is 50%.

Table 1. Physical and operational characteristics of the artificial wetland system

| Type of system | Horizontal subsurface flow |
|--|----------------------------|
| Shape | Four parallel-sized bed |
| Cell dimensions (m) | 12×20 |
| Total area (m ²) | 960 |
| Volume (m ³) | 235 |
| The slope of the surface layer of clay | 1% |
| Inflow (m ³ /day) | 40 |
| HRT (day) | 5.87 |
| HLR (m ³ /m ² . d) | 0.041 |
| OLR (Kg/ha .d Max) | 120–80 |
| Pretreatment | Septic tank |

Abbreviations: OLR, Organic Loading Rate

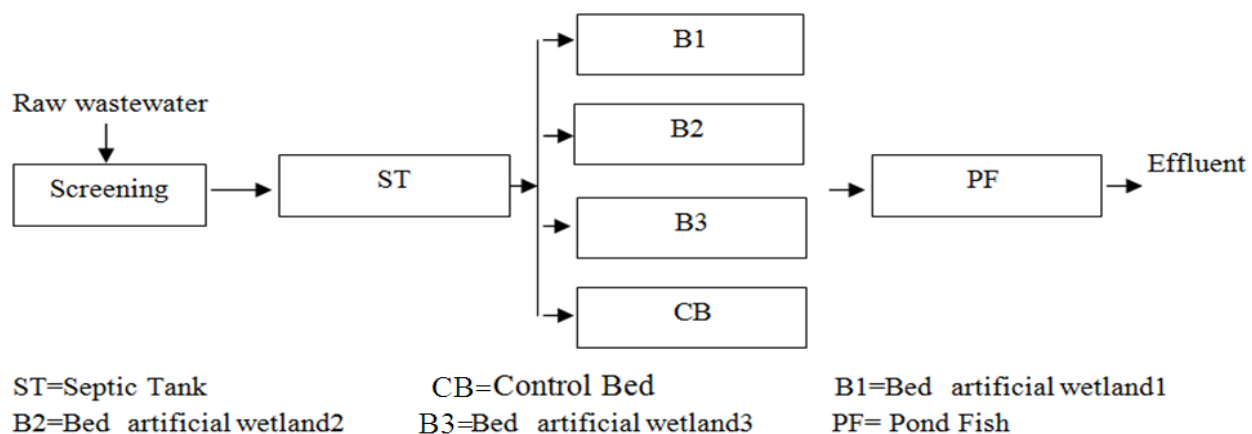

Figure 2. Schematic flow diagram for artificial wetland

Analyzed parameters

In order to determine all nutrients parameters, such as nitrogen, ammonia, nitrate, nitrite nitrogen, nitrogen Kjeldahl, orthophosphate, and total phosphorus, a total of 324 tests were conducted for 3 point system. Water and wastewater experiments were carried out based on the book of "Standard methods for the examination of water & wastewater" (17). After the wetland was sampled, the samples were measured with the standard method. All experiments in this research were conducted in Environmental Chemistry Laboratory, Health Department in Shahid Saadoughi University of Medical Sciences in Yazd. After collecting the data, a paired sample *t* test was done by SPSS (version 16). The figures were also drawn using Excel software. In this research, three pollutant removal models including the first-order, the second-order (grove), and Stover-Kincannon were used in order to investigate the kinetics of kinetic reactions in removing nutrients.

Kinetic models

First-order pollutant removal model

Given that this reaction is a first-order type for removing pollutants, changes in speed of removing pollutants in a reactor are expressed as below (16,18):

$$-\frac{dS}{dt} = \frac{Q}{V} \times S_i - \frac{Q}{V} \times S_e - k_1 S_e \quad (\text{Eq. 1})$$

In this equation, S_i and S_e are input and output substrate concentration per mg/L, and K_1 is the first-order kinetic constant. In stable conditions in the biological reactor, changes equal 0 in removing pollutant concentrations (d_s/d_t). Therefore, equation 1 can be written as follows:

$$\frac{S_i - S_e}{HRT} = k_1 S_e \quad (\text{Eq. 2})$$

In which *HRT* (Hydraulic Retention Time) is done per day. Thus, k_1 can be obtained from drawing $S_i - S_e/HRT$ against S_e based on the above equation (simplified version of equation 1). The slope value of the line equals k_1 .

Second-order pollutant removal model (Grove)

In fact, grove model shows the second-order kinetic which can be expressed as in the following (13,14):

$$\frac{S_i \times HRT}{S_i - S_e} = n \times HRT + m \quad (\text{Eq. 3})$$

Indeed, in order to simplify, it can be said that $S_i - S_e/S_i$ is practically the efficiency of removing pollutants in the system. So Instead of that, it is possible to put parameter *E* in the equation:

$$\frac{HRT}{E} = n \times HRT + m \quad (\text{Eq. 4})$$

By drawing the figure of equation 4, the values of *m* (per day) and *n* (without a unit) will be drawn as y-intercept and the slope of the line respectively. In the above-mentioned equation, *HRT* is per day. Pollutant removal speed constant or k_s is calculated by $m = S_i/k_s \times X$.

Stover-Kincannon model

This model is expressed as below in which U_{max} is the maximum speed of substrate removal g/l.day and K_B , saturation constant is g/l.day (16,18):

$$\left(\frac{dS}{dt}\right)^{-1} = \frac{V}{Q(S_i - S_e)} = \frac{K_B}{U_{max}} \left(\frac{V}{QS_i}\right) + \frac{1}{U_{max}} \quad (\text{Eq. 5})$$

By drawing $V/Q(S_i - S_e)$ per $V/Q \times S_i$, a straight line will be obtained. Its y-intercept and its slope will be the values of K_B/U_{max} and $1/U_{max}$ respectively. Thus, K_B and U_{max} values will be calculated.

Results

Nitrogen removal in artificial reed system depends upon system design, environmental chemistry (roots, plants, water and sediments), plant uptake, available carbon, and material type. Tables 2 and 3 show the mean efficiency of removing the studied parameters in the treatment plant using the method of artificial reed system with reeds and control reed system during three months of warm and three months cold study.

Stover-Kincannon model showed the above correspondence for removing nutrients in artificial reed system. Tables 4 and 5 indicate the statistical parameters of nitrogen and phosphorous removal with kinetic first-order, second-order (Grove), and Stover-Kincannon model in artificial reed system with reeds and that of control during the whole study. Stover-Kincannon model provided predictions having the closest relationship with actual data obtained from the field.

Discussion

Nowadays, it is proved that large aquatic plants (macrophytes) are able to help decompose human and animal

Table 2. The mean efficiency of removing studied parameters in all of the treatment plant using the method of artificial reed system during three months of warm study period

| Parameter | Input raw (mg/L) | Effluent from the blank (mg/L) | Effluent from the reed Bafgh (mg/L) | Removal (%) in the blank | Removal (%) in the reed Bafgh |
|--------------------------|------------------|--------------------------------|-------------------------------------|--------------------------|-------------------------------|
| NO ₃ -N | 1.93 | 1.64 | 1.46 | 15.02 | 24.55 |
| NH ₃ -N | 42.43 | 22.80 | 19.73 | 46.26 | 53.49 |
| Total kjehldahl nitrogen | 60.23 | 36.46 | 25.08 | 39.46 | 58.34 |
| Total phosphate | 7.90 | 6.14 | 5.20 | 22.27 | 34.17 |
| O-PO ₄ | 6.05 | 4.45 | 3.92 | 26.44 | 35.20 |

Table 3. The mean efficiency of removing studied parameters in all of the treatment plant using the method of artificial reed system during three months of cold study period

| Parameter | Input Raw (mg/L) | Effluent from the blank (mg/L) | Effluent from the reed Bafgh (mg/L) | Removal (Percent) in the blank | Removal (Percent) in the reed Bafgh |
|--------------------------|------------------|--------------------------------|-------------------------------------|--------------------------------|-------------------------------------|
| NO ₃ -N | 4.20 | 83.10 | 521.10 | 75.23 | 62.36 |
| NH ₃ -N | 4.41 | 39.24 | 26.20 | 41.80 | 51.60 |
| Total kjehldahl nitrogen | 54.85 | 84.45 | 75.32 | 41.46 | 71.61 |
| Total phosphate | 8.80 | 72.60 | 6.60 | 83.16 | 25.00 |
| O-PO ₄ | 37.60 | 184.50 | 7.40 | 61.18 | 2.26 |

Table 4. Kinetic parameters of nitrogen and phosphorous removal with different kinetic models in artificial reed system with reeds

| Kinetic Stover-Kincannon model | | | | |
|--|----------------|------------------|----------------|---------------------|
| Coefficients | K _b | U _{max} | R ² | Regression equation |
| Nitrogen removal | 37 | 1.65 | 0.942 | y = 0.482x + 0.013 |
| Phosphorous removal | 0.095 | 1.64 | 0.052 | y = 0.058x + 0.607 |
| The first-order kinetic model | | | | |
| Coefficients | K ₁ | | R ² | |
| Nitrogen removal | 0.302 | | 0.561 | y = 0.302x - 1.714 |
| Phosphorous removal | 0.032 | | 0.098 | y = -0.032x + 0.584 |
| The second-order kinetic model (Grove model) | | | | |
| Coefficients | m | n | R ² | Regression equation |
| Nitrogen removal | 160.2 | 1.2 | 0.856 | y = 2.100x - 2.160 |
| Phosphorous removal | 58.17 | 0.392 | 0.010 | y = 0.392x + 17.58 |

Table 5. Kinetic parameters of nitrogen and phosphorous removal with different kinetic models in control systems

| Kinetic Stover-Kincannon model | | | | |
|--|----------------|------------------|----------------|---------------------|
| Coefficients | K _b | U _{max} | R ² | Regression equation |
| Nitrogen removal | 8.53 | 35.71 | 0.745 | y = 0.239x + 0.028 |
| Phosphorous removal | 0.008 | 1.38 | 0.016 | y = 2.391x + 2.979 |
| The first-order kinetic model | | | | |
| Coefficients | K ₁ | | R ² | |
| Nitrogen removal | 0.091 | | 0.199 | y = 0.091x + 1.469 |
| Phosphorous removal | 0.155 | | 0.156 | y = -0.055x + 0.606 |
| The second-order kinetic model (Grove model) | | | | |
| Coefficients | m | n | R ² | Regression equation |
| Nitrogen removal | 0.673 | 2.436 | 0.329 | y = 2.100x - 2.160 |
| Phosphorous removal | 0.036 | 3.086 | 55.13 | y = 0.392x + 17.58 |

waste and remove pathogenic microorganisms along with many pollutants. Hence, plant systems have become more popular leading to a wider range of research in this regard as well (19).

The presence of wastewater can be unfavorable for several reasons. Nitrogen as free ammonia is toxic to fish and many other aquatic organisms. Nitrogen as ammonium ion or ammonia consumes oxygen, resulting in reduced dissolved oxygen in water. In terms of public health, the presence of nitrate ion in drinking water is a potential risk for children. Given the local circumstances and conditions, removing all forms of nitrogen and ammonium is necessary. In biological treatment systems, both of the above objectives can be achieved economically. All forms of phosphorus and nitrogen are regarded as a nutrient for

aquatic plants, and thus have a role in creating the phenomena called eutrophication.

In regard to the results obtained for nitrate nitrogen removal in the subsurface reed beds of Yazd wastewater treatment plant, mean removal was 31.17% (the mean warm season of 24.55% and mean cold season of 36.62%). Considering the nature of these systems and the results obtained from other studies, the removal rate in the studied artificial wetland is typical of most subsurface artificial wetlands.

Ammonification occurs in most of the artificial reed system designs under different common conditions, but high-rate nitrification needs average temperature, suitable pH for attached growth media, and enough oxygen. Total nitrogen falls by 46%–72% in most of reed systems. The

removal rate of total nitrogen varies depending on input nitrogen, water depth, dissolved oxygen, and loading rate of total nitrogen. The efficiency of total nitrogen removal reduces as hydraulic load increases (8). In a study carried out by Lee et al on an artificial reed system, it was found that TN removal rate was 10% to 24% (20). The study done in Sanandaj subsurface artificial wetland, showed that nitrogen removal was 5% to 51% depending on environment temperature (21). Regarding to the results obtained for removal of ammoniacal nitrogen in subsurface reed beds of Yazd wastewater treatment plant, mean removal was 52.29% (mean warm season 53.49% and mean cold season 51.06). Ammonia removal efficiency is almost independent on input concentration, and the maximum efficiency of hydraulic retention time takes at least 3-5 days. Typical removal efficiency at loading rate of less than 10 kg/ha per day is 70%–90% if other factors are not limiting. Reduced removal efficiency in higher loading rates can be due to the lack of dissolved oxygen, organic materials, and retention time. Background concentrations of ammonia are usually very low in reed systems. The most common target nitrogen pollutants in artificial reed systems are ammonia or total nitrogen whose rate depends on the flow input into reed systems. Effluent outputs of initial treatment and septic tank contain organic nitrogen and ammonia. A nitrogen removal cycle usually includes two main mechanisms, namely nitrogen transformation and nitrogen movement in reed systems. The two mechanisms consist of sedimentation (re-suspension) distribution in soluble forms, the influence of leaf litter, absorption/adsorption of dissolved nitrogen by soil particles, organisms migrating from reed systems, absorption by living organisms in reed systems, ammonification, ammonia volatilization, nitrification reactions/denitrification by bacterium, and nitrogen fixation. Sedimentation is not considered as an important process since nitrogen solubility even inorganic nitrogen is high. Since subsurface artificial reed systems are often anaerobic, microbial removal by nitrification is limited. Uptake by plants is limited as well. Almost low loaded systems are able to remove a part of ammonia. The sub-surface flow system situated in California has been able to remove nitrogen from initial treatment effluents, however for other SSF systems, removal was around 20% to 70%. Assuming that there is 20 to 25 mg/L in input nitrogen concentration (when retention time is more than 6-7 days), 10 mg/L of output effluent nitrogen concentration is expected to happen. Therefore, given the results obtained from many studies and complexity of removal processes, total nitrogen removal rate is at an acceptable level in Yazd artificial reed system. In regard to the results obtained for TKN removal in subsurface reed beds of Yazd city wastewater treatment plant, mean removal was 60.33% (the mean for warm season was 58.38% and for cold season was 61.71%). Gray et al (22) carried out a study in which TKN removal rate was measured by reed system process and was compared with similar conditions without any particular plant. Mean TKN removal for systems with plants was 30%. According

to the field data obtained for TP in artificial wetland beds, the mean removal was 29.53% (the mean for warm season was 34.17% and for cold season was 25%). Phosphorous removal rate in artificial wetland beds of Yazd city wastewater treatment plant was low. However, the results of other studies also emphasize low phosphorous removal rate in subsurface artificial reed system. Phosphorous removal in artificial reed system is not very effective with subsurface flow since there is a limited contact between absorption sites and wastewater under treatment. Depending upon loading rate, retention time, and bed material features, removal limit may vary between 10% and 40% for phosphorous input from 7–10 mg/L. A study done by Hamouri et al (23) reported that phosphorous rate for common reed plant was 15%. Rahmani et al (24) reported phosphorous removal rate of 9% in an artificial reed system with continuous flow and 17% for discontinuous flow. In another study done by Badhobi in Sanandaj city, phosphorous removal rate was 5%–55% at different temperature conditions (21). Greenway and Woolley found that phosphorous removal rates were 13% and 65% for a subsurface reed system and a single subsurface system respectively (25). Main methods of phosphorous removal in artificial wetland systems include precipitation and sedimentation caused by co-precipitation reactions with Ca-Fe-Al. The main factor in the sedimentation of phosphorous in most of artificial wetland systems is chemical adsorption of iron, aluminum and calcium complexes. The adsorption capacity of reed system soil can be estimated by laboratory analyses. The results of artificial wetland efficiency in polluted effluents treatment, reduced pollutants, and water pollution indices including municipal wastewater nutrients (nitrogen and phosphorous) have been studied by EPA in which the obtained removal limit was 30%–98% and 20%–90% for nitrogen and phosphorous respectively. Great changes observed in the efficiency of different parameters are due to climatic changes, differences in temperature, sunlight intensity and weakness, and differences in the physical condition of water level, water depth, and the type of plant (26). The methods for removing phosphorous in reed systems with subsurface flow are basically similar to that of surface flow reed systems. Making a big change in phosphorous adsorption requires a special environment. Phosphorous can be released at certain times of the year, which is usually caused by the changes of the system environmental conditions. Phosphorous removal limit for phosphorous input of 7-10 mg/L can be 10%–40%. Plant uptake is usually less than 10% (around 0.55 kg/ha per day) (27-29). The existing treatment plants may be investigated due to the fact that they cannot be directed as predicted and/or they must change for better performance. For example, they should be optimized in order to remove nutrients. Mathematical and biological models are used to determine the relationship between variables, so that designs and laboratory results could be analyzed using these relationships. These models are also used to control and predict the efficiency of treatment unit. Today, it is possible to reach the best

conditions of design, implementation, and operation by modeling. Using a model provides a series of completely novel methods for engineering practice and application. A model can be adjusted to fit data and then help designers and operators of mechanical and natural wastewater treatment systems by analyzing the alternatives in order to improve the process. Simplified models consist of a small number of variables and can be used to determine reaction kinetics. This research drew upon three pollutant removal models including the first-order, the second-order (Grove), and Stover-Kincannon order to examine biological reaction kinetics. The incapability of the traditional first order models, for capturing the diversity encountered in wetland systems could be attributed to their over simplified postulations such as: (a) the concentration of reactant (i.e. pollutant) is limited, and the presence of catalysts (i.e. microorganisms) is in excess, and (b) wastewater is assumed to follow plug flow approach in these systems, packed with substrates (16). In this system, the results showed that out of the three above-mentioned models, Stover-Kincannon was the most appropriate one for nitrogen removal. R^2 rate was found to be 0.942 for nitrogen. In this system, none of the above models were appropriate for phosphorous removal at an acceptable level. In regard to U_{max} rate obtained for nitrogen and phosphorous which were 76.98 mg/L and 1.64 mg/L per day respectively, it was found that these values were very low for phosphorous indicating its low consumption in this system. If system dimensions are smaller and input load is also higher, higher feed intake seems to be possible by the existence of more biomass. This hypothesis should be tested in controlled laboratory conditions and at a pilot or laboratory scale, so that a more precise evaluation of this kind of system will be possible. Kermani et al conducted a study on a MBBR system in which they found that U_{max} rate obtained from Stover-Kincannon model for the system under study was 43.305 and 35.088 per g/l.d for nitrogen and phosphorous respectively (18). In another study done by Pena et al (30) in a reactor loaded with upward flow, U_{MAX} rate was 12 g/l.d for nitrogen. Delnavaz et al (31) found that in a biomass reactor with a moving bed, U_{MAX} rate was 14.4 g/l.d for aniline removal. In analyzing the control system (without reeds), the results showed that Stover-Kincannon model was more appropriate than other models in this system with respect to nitrogen removal. R^2 coefficient rate was 0.745 in nitrogen removal for Stover-Kincannon model.

Conclusion

Untreated wastewater can create many environmental problems. Low-tech wastewater treatment systems consuming no energy or low-consuming systems improve our environment in addition to reduction of economic costs. The results of experiments showed that the nutrients removal rate of wetland system with reeds was higher than that of the control system, but this difference was not significant. Statistical data analysis also revealed that there was no significant relationship between the removal effi-

ciency of the control system and the system with reeds at confidence level of 95% ($P > 0.05$). So, the results showed that the presence of reeds in wetland beds has not been very effective in improving the system performance, and plants with more ability of removal in the system are suggested to be examined (phragmites). Generally, proper performance and high removal at the first unit (septic tank) increases the efficiency of treatment plant and in the same way reduces the input load. The presented results show that Yazd city wastewater treatment plant, due to favorable conditions, has created a situation in which many of the main pollution index parameters fall significantly. In regard to predicting the behavior of nutrients removal, Stover-Kincannon model presented the closest mathematical relationship between theoretical predictions and the actual field data.

Acknowledgments

The authors highly appreciate the sponsorship of Yazd Water and Wastewater Company and Iran University of Medical Sciences.

Ethical issues

We certify that all data collected during the study is presented in this manuscript and no data from the study has been or will be published separately.

Competing interests

The authors declare that they have no competing interests.

Authors' contributions

MF, MK, MHE, and EAM conceived and designed the study. EAM and MK performed the literature search and wrote the manuscript. All authors participated in the data acquisition, analysis, and interpretation. All authors critically reviewed, refined, and approved the manuscript.

References

1. Neralla S, Weaver RW, Lesikar BJ, Persyn RA. Improvement of domestic wastewater quality by subsurface flow constructed wetlands. *Bioresour Technol* 2000; 75(1): 19-25.
2. Reed SC, Crites RW, Middlebrooks EJ. *Natural systems for waste management and treatment*. McGraw-Hill; 1998.
3. Steer D, Fraser L, Boddy J, Seibert B. Efficiency of small constructed wetlands for subsurface treatment of single-family domestic effluent. *Ecol Eng* 2002; 18(4): 429-40.
4. Vymazal J. The use of sub-surface constructed wetlands for wastewater treatment in the Czech Republic: 10 years experience. *Ecol Eng* 2002; 18(5): 633-46.
5. Crites RW, Technobanoglous G. *Small and decentralized wastewater management systems*. McGraw-Hill; 1998.
6. Kadlec RH, Wallace S. *Treatment wetlands*. 2nd ed. Boca Raton: CRC Press; 2008. p. 950.

7. Stephen P, Faulkner SP, Richardson CJ. Physical and chemical characteristics of freshwater wetland soils. In: Hamner DA, (ed). *Constructed Wetlands for Wastewater Treatment: municipal, industrial and agricultural*. Chelsea, MI: Lewis Publishers; 1989. p. 41-72.
8. Davenport JC, Annie K, Christiane MR. Wetlands at Work. In: *Waves, Wetlands, and Watersheds: California Coastal Commission Science Activity Guide*. San Francisco, CA: Commission; 2003. p. 30-34.
9. Rousseau DP, Vanrolleghem PA, De Pauw N. Constructed wetlands in Flanders: a performance analysis. *Ecol Eng* 2004; 23(3): 151-63.
10. Jenssen PD, Krogstad T. Design of constructed wetlands using phosphorus sorbing lightweight aggregate (LWA). In: Mander Ü, Jenssen PD, (eds). *Constructed wetlands for wastewater treatment in cold climates*. Southampton, UK: WIT Press; 2003. p. 259-71.
11. Cui LH, Ouyang Y, Zhu XZ, Zhu WL. Removal of total nitrogen by *Cyperus alternifolius* from wastewaters in simulated vertical-flow constructed wetlands. *Ecol Eng* 2009; 35(8): 1271-4.
12. Liao X, Luo S, Wu Y, Wang Z. [Comparison of nutrient removal ability between *Cyperus alternifolius* and *Vetiveria zizanioides* in constructed wetlands]. *Ying Yong Sheng Tai Xue Bao* 2005; 16(1): 156-60. [In Chinese]
13. Mayo AW, Bigambo T. Nitrogen transformation in horizontal subsurface flow constructed wetlands I: model development. *Physics and Chemistry of the Earth, Parts A/B/C* 2005; 30(11-16): 658-67.
14. Brooks AS, Rozenwald MN, Geohring LD, Lion Lw, Steenhuis TS. Phosphorus removal by wollastonite: a constructed wetland substrate. *Ecol Eng* 2000; 15(1-2): 121-32.
15. Miranzadeh MB, Mahvi AM, Mesdaghinia AR, Naseri S. Efficiency study for integrated stabilization pond (ISP) in municipal wastewater treatment. *Feyz* 2000; 4(1): 43-54. [In Persian]
16. Davoodi R. Kinetic modeling of wastewater treatment system to remove organic materials of nitrogen and phosphorus in artificial wetland city of Qasr-e Shirin [dissertation]. Tehran: Tehran University of Medical Sciences; 2010.
17. Eaton AD, Franson MA. *Standard methods for the examination of water & wastewater*. American Public Health Association; 2005.
18. Kermani M, Bina B, Movahedian H, Amin MM, Nik Aein M. Performance analysis and modeling, moving-bed biofilm process to remove nutrients from wastewater compounds. *Journal of Water and Wastewater* 2009; 21(3): 9-19.
19. Kadlec HR, Wallace DS. *Treatment wetlands*. 2nd ed. USA: CRC Press; 2009.
20. Lee CY, Lee CC, Lee FY, Tseng SK, Liao CJ. Performance of subsurface flow constructed wetland taking pretreated swine effluent under heavy loads. *Bioresour Technol* 2004; 92(2): 173-9.
21. Badhobi A, Ranaee F. Reed and Microorganisms growth wastewater in artificial wetland. Environmental effects of agricultural wastewaters conference on groundwater and surface water, 2001.
22. Gray S, Kinross J, Read P, Marland A. The nutrient assimilative capacity of maerl as a substrate in constructed wetland systems for waste treatment. *Water Res* 2000; 34(8): 2183-90.
23. Hamouri BE, Nazih J, Lahjouj J. Subsurface-horizontal flow constructed wetland for sewage treatment under moroccan climate conditions. *Desalination* 2007; 215(1-3): 153-8.
24. Rahmani A, Azimi A, Mehrdadi N. Survey performance integrated anaerobic ponds Equipped with whole digester and subsurface artificial wetland for subsurface municipal wastewater treatment. *Desalination* 2009; 3(1): 18-27.
25. Greenway M, Woolley A. Constructed wetlands in Queensland: performance efficiency and nutrient bioaccumulation. *Ecol Eng* 1999; 12(1-2): 39-55.
26. Hammer DA, Knight RL. Designing constructed wetlands for nitrogen removal. *Water Sci Technol* 1994; 29(4): 15-27.
27. Akrotos CS, Papaspyros JN, Tsihrintzis VA. An artificial neural network model and design equations for BOD and COD removal prediction in horizontal subsurface flow constructed wetlands. *Chem Eng J* 2008; 143(1-3): 96-110.
28. Vymazal J, Kröpfelová L. *Wastewater treatment in constructed wetlands with horizontal sub-surface flow*. Netherlands: Springer science & business media; 2008. p. 278-331.
29. Mofayezi A. *Natural wastewater treatment systems*. Mashhad: Marandiz; 2009. [In Persian]
30. Pena MR, Rodríguez J, Mara DD, Sepulveda M. UASBs or anaerobic ponds in warm climates? a preliminary answer from Colombia. *Water Sci Technol* 2000; 42(10-11): 59-65.
31. Delnavaz M, Ayati B, Ganji Dost H. Reaction kinetics of aniline synthetic wastewater treatment by moving bed biofilm reactor. *Environmental Health Science* 2010; 2(1): 76-87. [In Persian]